

# PA-M52Hv Mobile DVR



## 8 Channel video recording

Built-in Speaker, support one-way audio function.

Support  
2 x SD cards.  
2 x SIM cards.

Solid  
Hard Drive.

3/4G network,  
GPS/BD  
positioning  
technology

PA 1607  
INTERNAL DOME

PA 1522  
DUAL CAMERA

PA AC 5881 AHD  
BOX REAR VIEW

PA 1509 IR AHD  
SINGLE CABIN VIEW

PA 1612  
SINGLE ROAD VIEW

PA 1524  
SIDE VIEW

**COMPATIBLE AVAILABLE CAMERAS**

12 Month Warranty

**360°** Truck & Trailer

# Recorded Driver & Fleet Monitoring.

**PROTECT YOUR FLEET**  
Get Your Quote Today!

## PA-M52Hv Mobile DVR



PA-M52Hv is designed for vehicle video monitoring, remote video monitoring development of a high performance, high expansion and extension of the product, the use of hard disk can be self-pop-up structure design and high-speed processor NT98323 and embedded operating system, integration of IT cutting-edge field H.264/H.265 video compression/decompression, 3/4G network, GPS/BD positioning technology. It has the characteristics of strong earthquake resistance, simple appearance, flexible and convenient installation, comprehensive function and high reliability. Suitable for public security police, financial escort, long-distance passenger transport, road administration inspection and other vehicle movement monitoring fields.

### Key features:

- The interface can operate reliably and stably in complex environments Video encoding H.265, H.264
- is optional
- Support 3/4G WIFI and GPS functional modules
- Supports a 2.5-inch optional SSD/HDD hard disk
- Supports one SD card
- Rich peripheral interfaces
- Support external UPS battery life
- High Scalability



# 360° Truck & Trailer

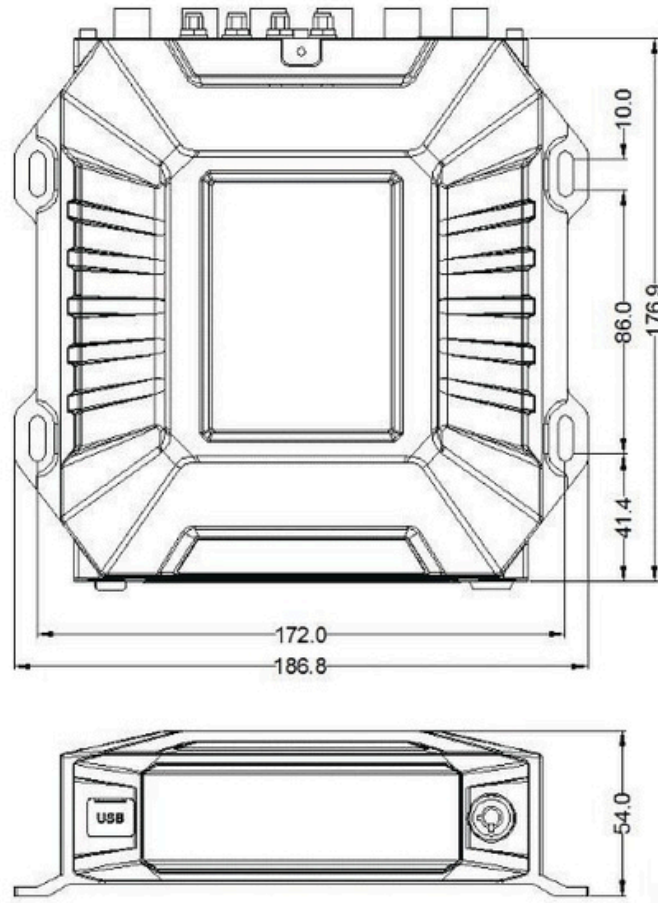

**Panel & interface**

**Front panel**

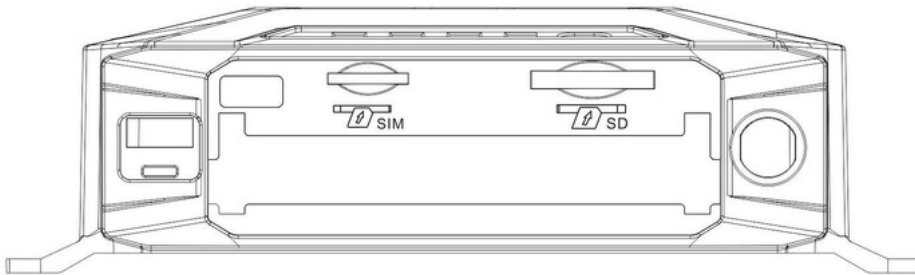

**Rear panel**

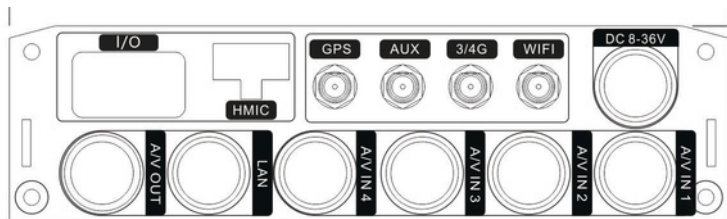

## Specification:

Audio and Video Inputs	Video Input	8chAHD video input
	Audio Input	4ch audioinput
Audio and Video Outputs	Video Output	Default 1-way CVBS output (VGAoutput optional)
	Audio Output	1ch audiooutput
Audio and Video Parameter Coding	Video Coding	H.264 Main Profile/H.265
	Resolution	1080P/720P/D1optional
	Audio Coding	Default G.726,G.711A optional
Storage	HDD	1x 2.5-inch optional: SSD/HDD hard disk
	SD	Support 1x SD card
Wireless Network	3/4G	Supports 1 x SIM card, 4G optional: all major communication modules in the world
	WIFI	2.4/5.8G optional
Locate Mode	BD/GPS	Support for mixedpositioning, speed detection, timesynchronization
Interface	USB	USB 2.0 interface,support exportdata
	Serial Port	Support 2x RS232, 1x RS485, can beconnected with external sensor
	I/O	4level inputs, 2analog inputs,2 alarmoutputs
	Network Interface	Support external IPC, support hybrid NVR function
	Intercom	1x special intercomhandheld markinterface
Physical Specifications	Size	176.9mm (L) *186.8mm (W) *54mm (H)
	Weight	NW : 1.4k g GW: 2kg (PA-M52Hv-DGNE1-Las a standard)
Work Environment	Operating Temperature	-20~70°C
	Operating Humidity	8%~90% (No condensation )
Other	Operator Schema	remote control、APP、WEB
	Gravity Sensor	Built-in G-Sensor
	Optional ConfigurableAI Algorithms	Face recognition 、 People Counting、 ADAS+DMS

## 720P AHD Metal Box Camera

Model: **PA 1612**  
**High resolution, 2.1mm Megapixel, 12VDC**

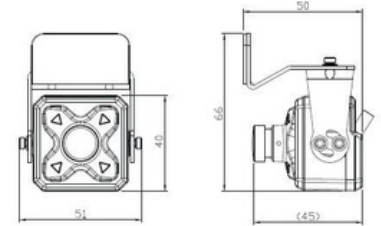

**Dimensions:**

Model: **PA 1612**  
 High resolution, 1.3Mega Pixel, 12V DC

**Features:**

- All metal-cased mini housing with megapixel fixed lens.
- Low power consumption.
- Any light environment can show the true color reduction.
- Easy installation.

**Operation procedures:**



1. Remove the lens cap(1).
2. Tear off 3M glue from covering layer, fixed the camera on the right location.
3. Connect the camera to 4pin jack as below diagram.



4. Adjust camera position by loosening the fixed screw (4). Adjust the focus sharpness of the lens(2) by loosening the focus-lock screw(3).
5. Re-tighten all the fixed screws.

**Specifications:**

Model	PA 1612
ImageSensor	1/3" CMOS AR0130
TVSystem	PAL/NTSC (optional)
PictureElements	1280 (H) x 960 (V)
Sensitivity	0.1 Lux/F1.2
ScanningSystem	Progressive scan RGB CMOS
Synchronization	Internal
S/NRatio	More than 44dB (AGC Off)
AutoGainControl(AGC)	Auto
ElectronicShutter	Auto
BLC	Auto
InfraredSpectrum	N/A
InfraredLED	N/A
Video Output	1 Vp-p, 75Ω, AHD
AudioOutput	Optional
Mirror	Optional
NoiseReduction	3D
Dynamicrange	83.5 dB
Lens	2.1mm Megapixel
Power Supply	12V DC±10%
PowerConsumption	60mA (Max)
Dimensions	51 (L) x 66(W) x 50 (H) mm
NetWeight	108g
Weatherproof/WaterProof	N/A
Operating Temperature	-30° C ~ +70 ° C

*\*Specifications are subject to change without prior notice.*

**Packing list:**

Camera	1
Instruction manual	1
Mounting Screw	2
Hex-key	1



Extention Camera Cable and converter cable at additional costs.

Extention Camera Cable available in 5m.



Extension Camera Cable and converter cable at additional costs.

Extension Camera Cable available in 5m.

# PA 1522

## Dual Camera

Model: **PA 1522**

**High resolution, 2.5mm Megapixel, 12VDC**

### Features:

- Aluminium alloy housing.
- Wide angle lens.
- Cam 2 Option 120dB Real WDR.
- Strong light inhibition.
- Cam 1 Build-in IR LED.
- Cam 1 Audio output.



### Packing list:

Camera	1
Instruction Manual	1
Hex-key	1

### Operation procedures:

1. Adjust the position of (1) to change the angle of inner-forwarding camera 1.
2. Adjust the position of (2) to change the angle of out-forwarding camera 2.
3. Take off the 3M sticker of (3) to fix the whole camera to needed place.
4. Connect the cable as below.

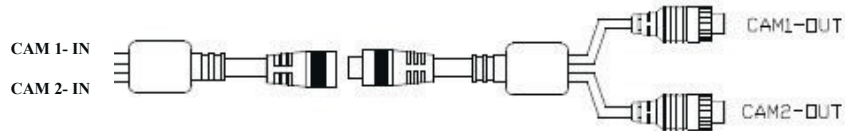
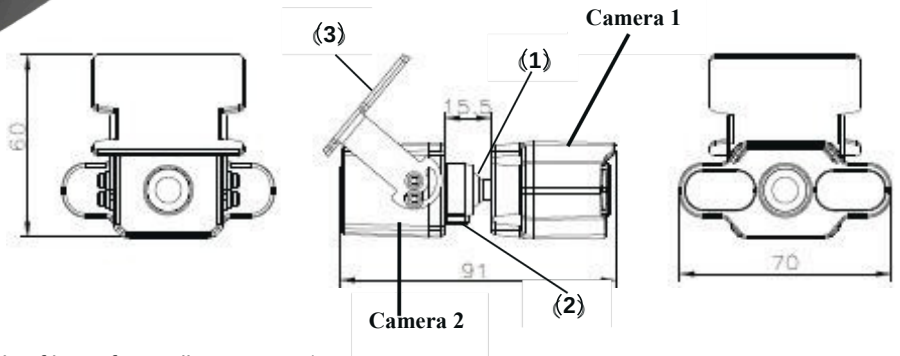

### Specifications:

## Specifications

#### Camera1(Cabin Facing)

Image Sensor	1/3"CMOSAR0130 PAL/NTSC
TV System	(optional)
Picture Elements	1280(H) x960(V)
Sensitivity	0 Lux(IR LED On) Progressive
ScanningSystem	scan RGB CMOS Internal
Synchronization	Morethan44dB(AGC Off) Auto
S/NRatio	Auto
AutoGain Control(AGC)	Auto
ElectronicShutter	850nm
BLC	6LEDs
Infrared Spectrum	1 Vp-p,75Ω,AHD
Infrared LED	Available
Video Output	Optional
Audio	Available
Mirror	3D
ICR	83.5dB
NoiseRedution	2.5mmMegapixel
Dymamicrange	
Lens	
PanAdjusting	0-50°
Tilt Adjusting	0-50°
Power Supply	9-18V DC
Power Consumption	110mA
Weatherproof/Water Proof	N/A
Operating Temperature	-30°Cto+70°C

#### Camera2(Road Facing)

Image Sensor	1/3" CMOS AR0130
TV System	PAL/NTSC (optional)
Picture Elements	1280(H) x960(V)
Sensitivity	0.1Lux/F1.2
ScanningSystem	Progressive scan RGB CMOS
Synchronization	Internal
S/NRatio	More than 44dB (AGC Off)
AutoGain Control(AGC)	Auto
ElectronicShutter	Auto
BLC	Auto
Infrared Spectrum	N/A
Infrared LED	N/A
Video Output	1 Vp-p,75Ω,AHD
Audio	N/A
Mirror	Optional
ICR	N/A
NoiseRedution	3D
Dymamicrange	83.5dB
Lens	f2.5mmMegapixel
PanAdjusting	N/A
Tilt Adjusting	0-80°
Power Supply	9-18V DC
Power Consumption	70mA
Weatherproof/Water Proof	N/A
Operating Temperature	-30°Cto+70°C

# PA 1509 IR AHD

## 720P AHD Colour Mini Taxi Camera



Model: **PA 1509 IR AHD**  
**High resolution, 1.3Mega Pixel, 12VDC**

### Dimensions:

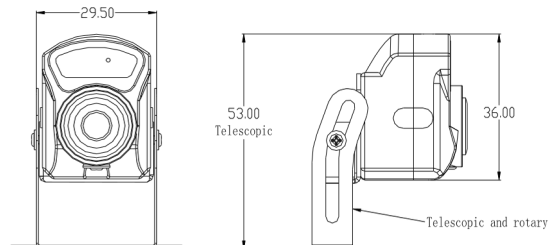

### Features:

- Metal-cased mini housing with standard fixed lens.
- Available in black finish.
- Low power consumption.
- Easy installation on ceiling or wall, surface or flush mount.

### Operation procedures:

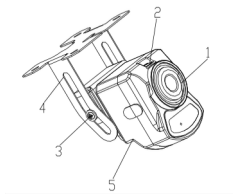

1. Attach the mounting bracket (4) to wall or ceiling, as required. Use the supplied screws to fix camera (5) in position ~ a firm mounting surface is essential for a stable installation.
2. Connect the camera as follows:

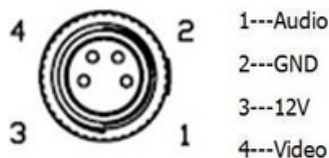

3. Adjust camera position by loosening the fixed screw (3). Adjust the focus sharpness of the lens (1) by loosening the focus-lock screw (2).
4. Re-tighten the all fixed screws.

### Specifications:

Model	PA 1509 IR AHD
Image Sensor	1/3" CMOSAR0130
TV System	PAL/NTSC (optional)
Picture Elements	1280 (H)x960(V)
Sensitivity	0 Lux (IRLEDOn)
Scanning System	Progressive scanRGBCMOS
Synchronization	Internal
S/N Ratio	More than 44dB(AGCOff)
Auto Gain Control (AGC)	Auto
Electronic Shutter	Auto
BLC	Auto
Infrared Spectrum	940nm
Infrared LED	6 LEDs
Video Output	1 Vp-p, 75Ω,AHD
Audio	Available
Mirror	Optional
ICR	N/A
Noise Redution	3D
Dynamic range	83.5 dB
Lens	f2.35mm Megapixel
Power Supply	9-18VDC
Power Consumption	100mA
Dimensions	36(L) x 29.5 (W)x53(H) mm
Net Weight	51g
Weatherproof	N/A
Operating Temperature	-30°C to+70°C

*\*Specifications are subject to change without prior notice.*



Extention Camera Cable and converter cable at additional costs.

Extention Camera Cable available in 5m.

### Packing list:

Camera	1
Instruction manual	1
Adhesive EPE type	1
Mounting screw	4

# PA 1524 IR

720P / 1080P, 12V DC, F2.8mm / F3.6mm SIDE CAMERA

Model: **PA 1524 IR**  
**High resolution, 2.8mm Megapixel, 9-18V DC**

## Specifications:

Model	PA 1524 IR
Image Sensor	Nextchip2441+ 1/2.9"IMX323
TV System	PAL/NTSC (optional)
Picture Elements	1920 (H) x 1080 (V)
Sensitivity	0 Lux (IR LED On)
Scanning System	Progressive scan RGB CMOS
Synchronization	Internal
S/N Ratio	More than 52dB (AGC Off)
Auto Gain Control (AGC)	Auto
Electronic Shutter	Auto
BLC	Auto
Infrared Spectrum	850nm
Infrared LED	12 LEDs
Video Output	1Vp-p, 75Ω, AHD
Audio	N/A
Mirror	Optional
ICR	IRCUT
Noise Reduction	3D
Lens	f2.8mm Megapixel
Power Supply	9-18VDC
Power Consumption	180m A
Dimensions (L X W X H)	90 X 77 X 63.5mm
Net Weight	286g
Weather proof	IP67
Operating Temperature	-30°C to +70°C

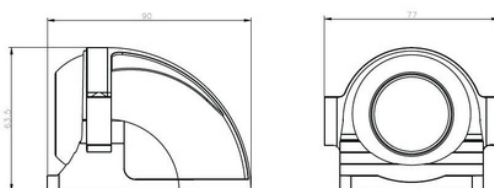

## Packing list and dimensions:

Camera	1
Instruction Manual	1
Mounting Screw	4

## Cable Connection:



- 1---12VDC (+)
- 2---12VDC/GND (-)
- 3---Audio or N/A
- 4---Video



Extention Camera Cable and converter cable at additional costs.

Extention Camera Cable available in 5m.

## 720P AHD Colour Mobile Box Camera

Model: **PA AC 5881 AHD**  
Analog AHD, 1.3Mega Pixel, 12V DC



### Features:

- Metal-cased mobile box with fixed lens.
- Available in black finish.
- Low power consumption.
- Easy installation on ceiling or wall, surface or flush mount.
- IP67 waterproof.

### Specifications:

Model	PA AC 5881 AHD
Pick up Device	1/3" CMOS AR0130
TV System	PAL/NTSC (Optional)
Picture Elements	1280 (H) x 960 (V)
Sensitivity	0 Lux (IR LED On)
Scanning System	Progressive scan RGB CMOS
Synchronization	Internal
S/N Ratio	More than 44dB(AGC Off)
Auto Gain Control (AGC)	Auto
Electronic Shutter	Auto
Back Light Compensation	Auto
Infrared Spectrum	850 nm
Infrared LED	18 LEDs
Mirror	Available
ICR	Available
Noise Reduction	3D
Dynamic range	83.5 dB
Video Output	1 Vp-p, 75Ω,AHD
Audio Output	Optional
Lens	f2.8mm Megapixel
Pan Adjusting	N/A
Tilt Adjusting	0-60 Degree
Power Supply	9-18V DC
Power Consumption	180mA
Dimensions (L X W X H)	L69 x W76 x H78 mm
Net Weight	285g
Weatherproof	IP67
Operating Temperature	-30~ +70 ° C

*\*Specifications are subject to change without prior notice.*

### Dimensions:

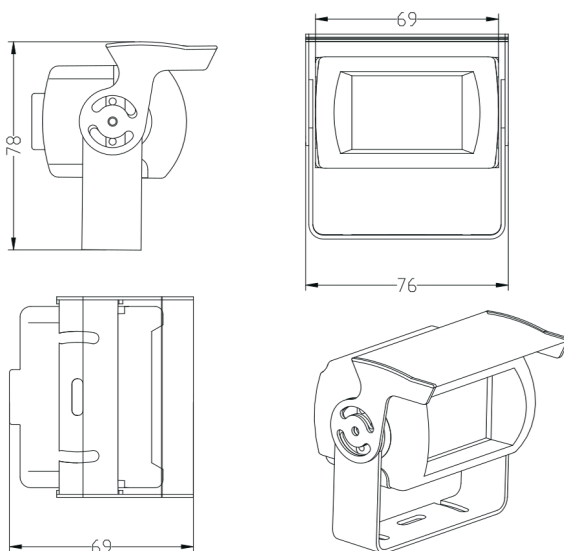

### Operation procedures:

1. Loosen the lock screws on the sun shield, remove the mounting bracket to the suitable position.
2. Attach the mounting bracket to the wall or ceiling, wherever you want to install the camera. Locate a wall stud or ceiling joint and secure the base by the supplied mounting screws.
3. Connect the cable to DC12V power input and video output.
4. Fix the lock screw.

### Cable Connection:

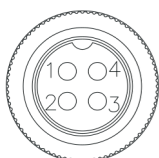

- 1---12VDC (+)
- 2---12VDC/GND (-)
- 3---N/A
- 4---Video



Extension Camera Cable and converter cable at additional costs.

Extension Camera Cable available in 5m.

### Packing list:

Camera	1
Instruction Manual	1
Self Drilling Screw	2
Hex-key	1



Model: **PA 1607**  
**High resolution,AHD,DC12V+/-20%**

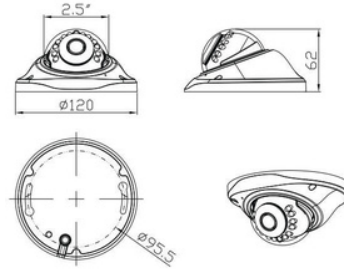

### Specification

<b>Model</b>	<b>PA 1607-960 IR 1080P AHD</b>
ImageSensor + DSP	1/2.7" CMOS AHD
PicturePixels	1920(H)*1080(V)
Video FrameRate	PAL: 1080p@25fps,NTSC: 1080p@30fps
Video Output	AHD
TransmissionDistance	More than 500m via 75-3 coaxial cable
MinimumIllumination	Day: 0.01Lux, 0Lux (IR ON)
Lens	2.8m m
Sync System	Internal Synchronization
Electronic Shutter	PAL: 1/25 -1/50,000 Sec, NTSC:1/30 -1/60,000 Sec
S/N Ratio	More than 50dB
Day and Night	Auto(ICR) /Color /B/W
Infrared LED	12mil*Φ5*12pcs LEDs
IR Distance	10-15m
OSD Menu	Support
UTC	Support
OSD/UTC Language	EN, CN, DE, FRA, IT,ES,PL, RU,PT,NL, TR
D-W DR	Support
Noise Reduction	3DNR
White Balance	Auto/ Manual
Gain Control	Auto
Operation Temperature	-20°C~+70°C /Less than 95%RH (Nocondensation)
Power Supply	DC12V+/-20%
Dimension	Φ120*62mm
Housing	Ivory color metal case
Audio	Audio Optional



Extention Camera Cable and converter cable at additional costs.

Extention Camera Cable available in 5m.